

**Marimba One™**

**One Vibe**  
**OWNER'S MANUAL**

### FOR ASSEMBLY, YOU WILL NEED:

- A large open space with carpet (or a blanket to cover the floor)
- An assistant to help you with assembly

## 1 CAREFULLY UNPACK YOUR CRATE

Compare the seven components as shown on this page.

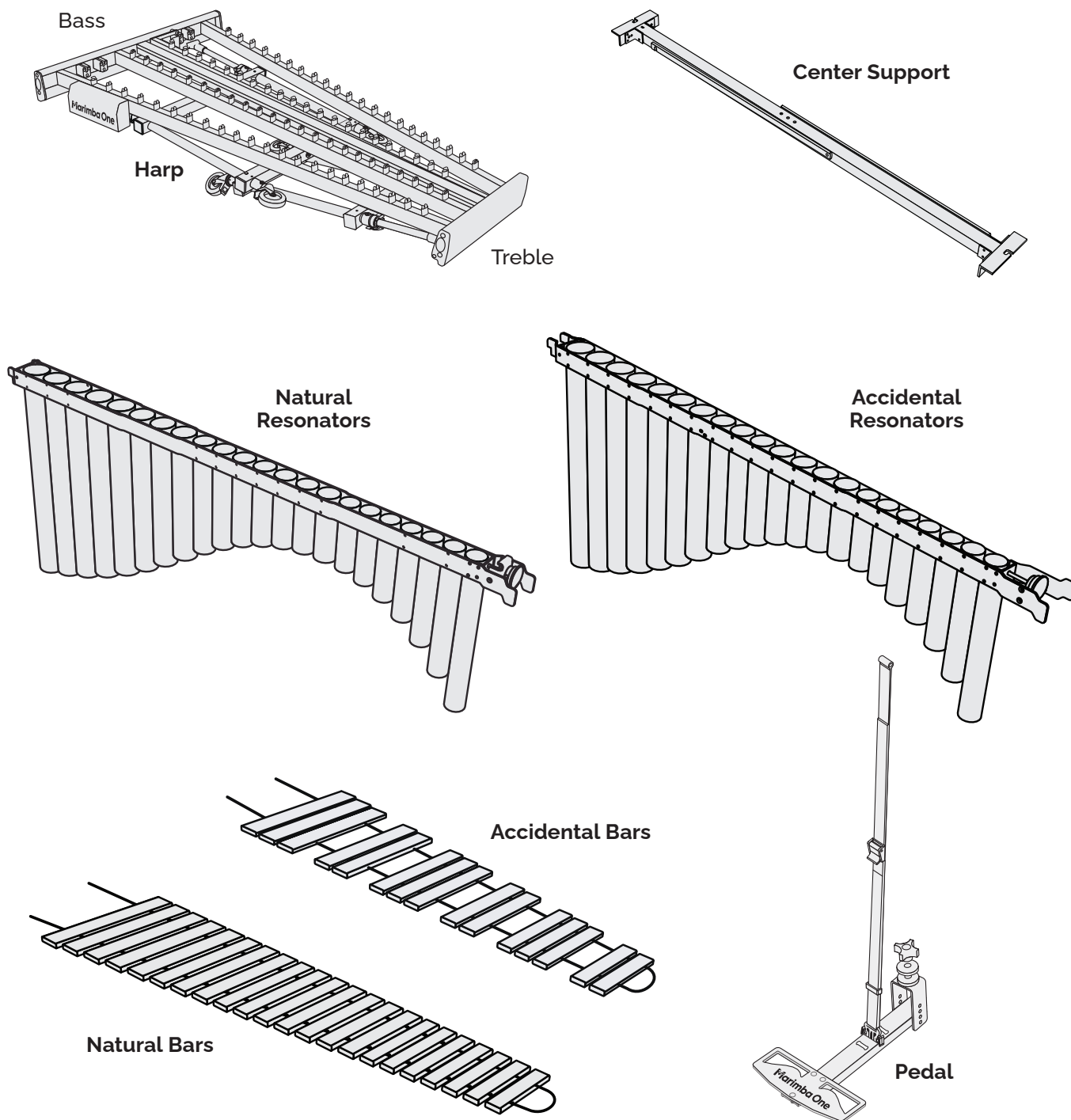

## CENTER SUPPORT

2

### UNFOLD LEGS

Position yourself with the bass end on your left and treble end on your right, with legs facing you. Pull legs toward you.

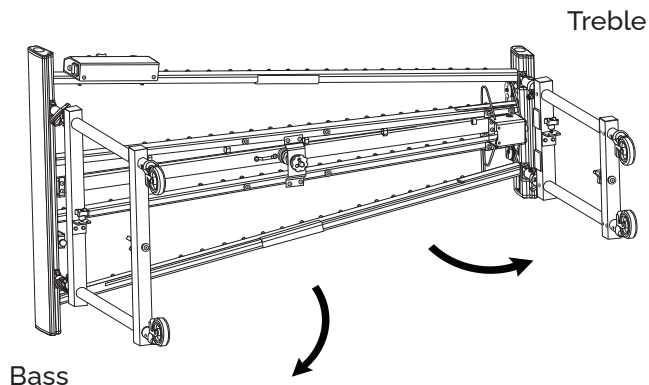

3

### IDENTIFY BASS END OF CENTER SUPPORT

Bass end is engraved with the letter B on bottom of the center support.

Align *bass end* of center support with *bass end* of harp.

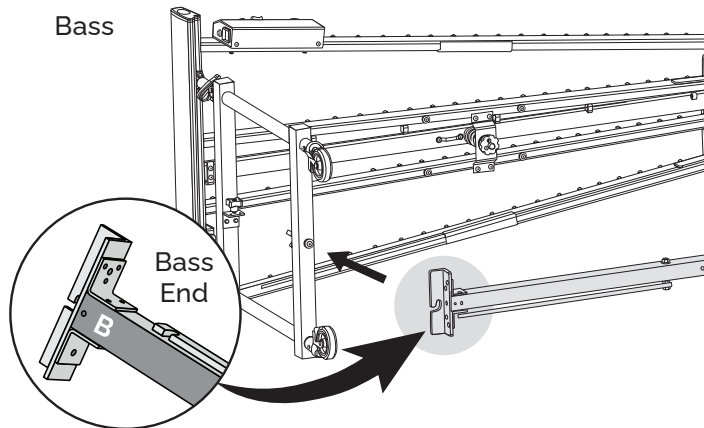

4

### UNFOLD ARMS

Unfold arms by swinging them over to the opposite side.

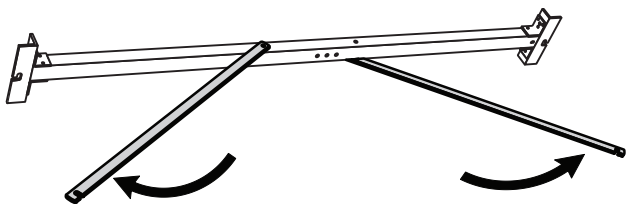

5

### POSITION CENTER SUPPORT

Insert center support through legs of both endframes.

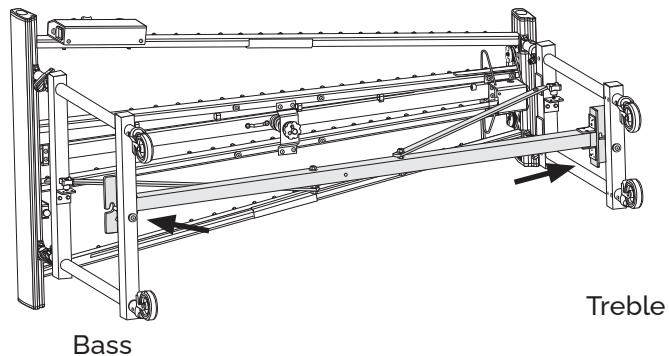

6

### ATTACH BASS END

Slide notch onto bolt.

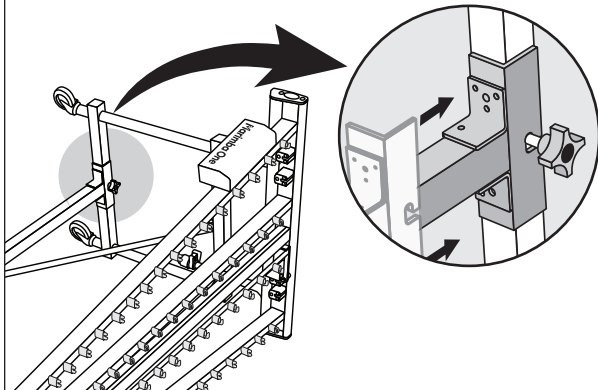

7

### TIGHTEN KNOB

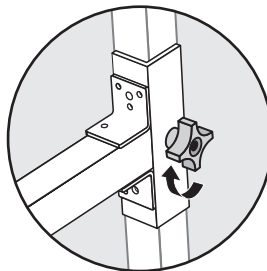

8

### REPEAT FOR TREBLE END

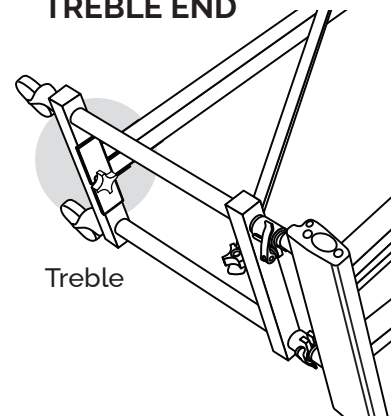

9

**ATTACH ARMS**

Rotate arm and slide notch onto bolt.

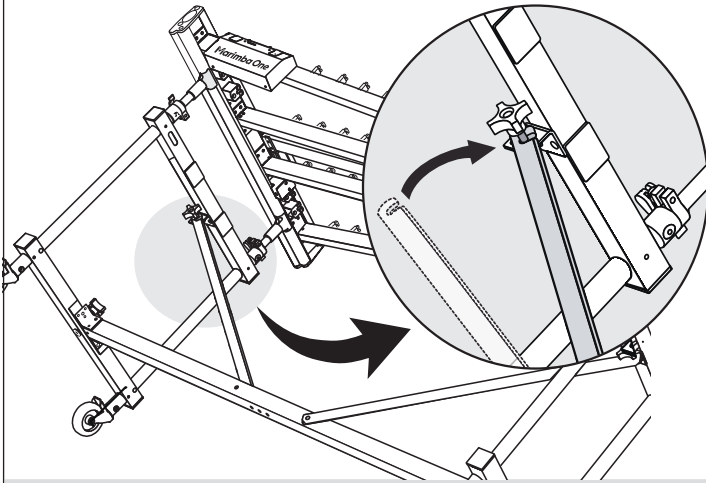

10

**TIGHTEN KNOB**

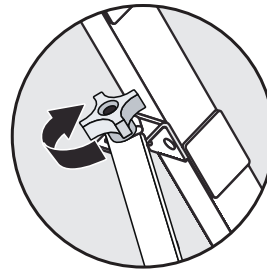

11

**REPEAT FOR OTHER ARM**

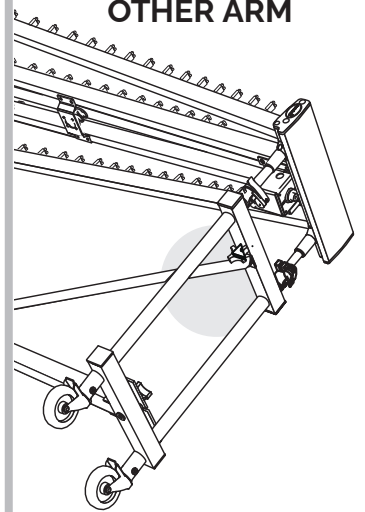

**PEDAL**

12

**REMOVE PARTS**

Remove knob, metal washer, and *one* black plastic washer.

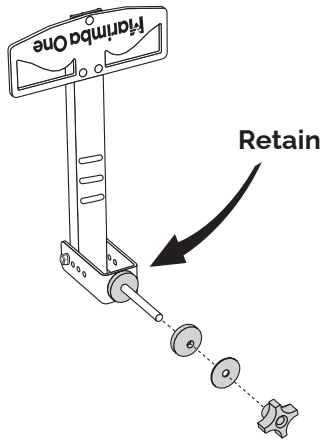

13

**INSERT PEDAL BOLT**

Slide pedal bolt through hole on center support.

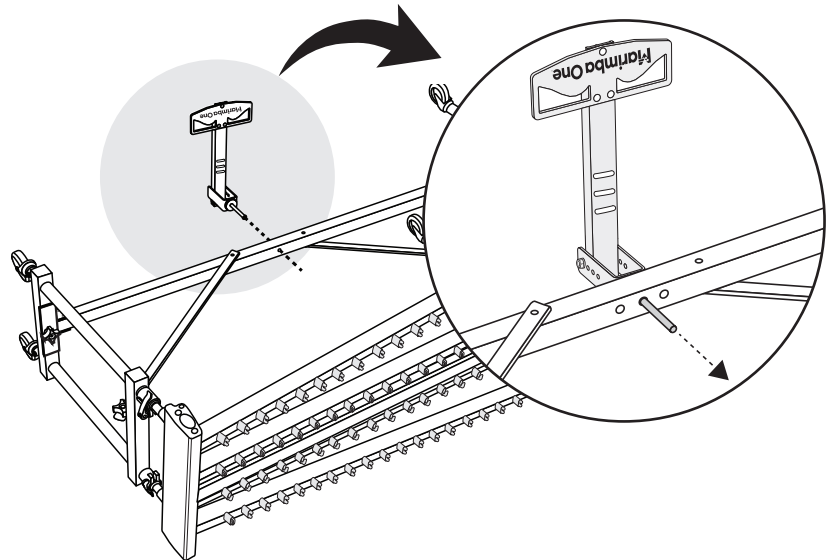

14

**SECURE PEDAL**

In the following order, place black plastic washer, metal washer, and knob onto bolt.

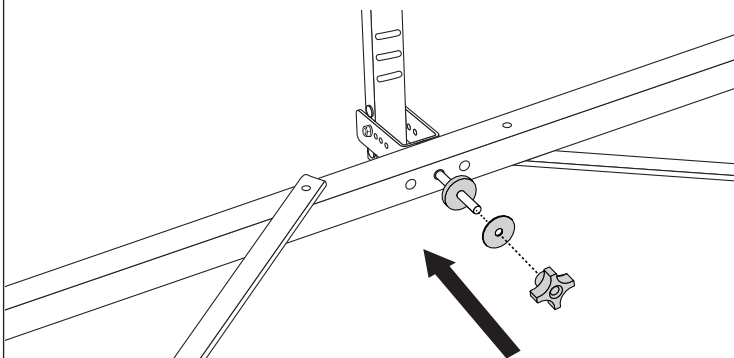

15

**TIGHTEN KNOBS**

Tighten knob until desired tension is reached.

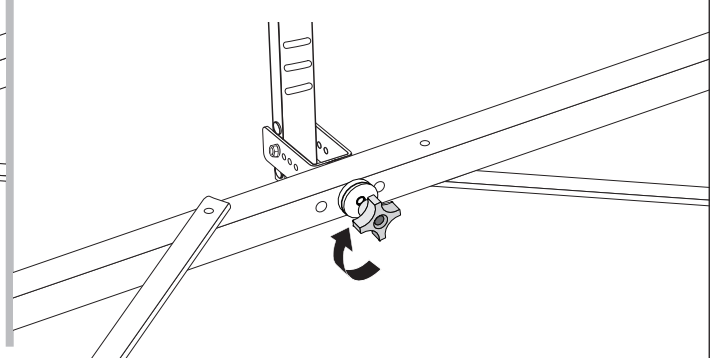

16

**ATTACH STRAP TO PEDAL**

Insert strap clip into slot on pedal.

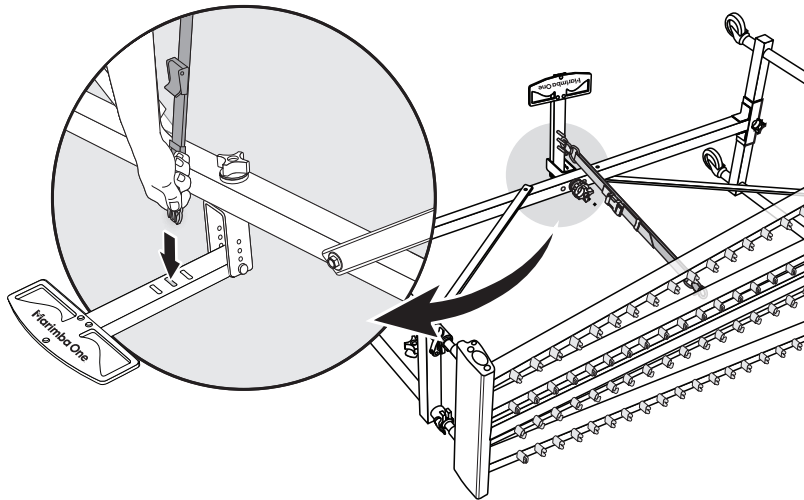

17

**PLACE HARP IN UPRIGHT POSITION**

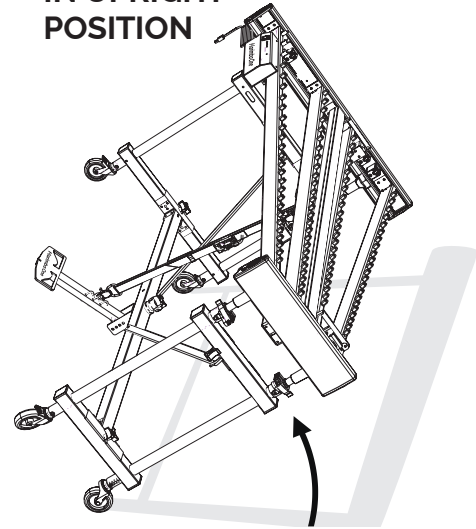

**RESONATORS**

18

**IDENTIFY NATURAL RESONATOR BANK**

The natural resonator bank has a plug inside every tube. The accidental resonators are missing a plug in every 3rd or 4th tube.

19

**POSITION TREBLE END OF NATURAL RESONATORS**

First, position treble end of natural resonators into treble endframe. *Natural resonators have plugs in every tube.*

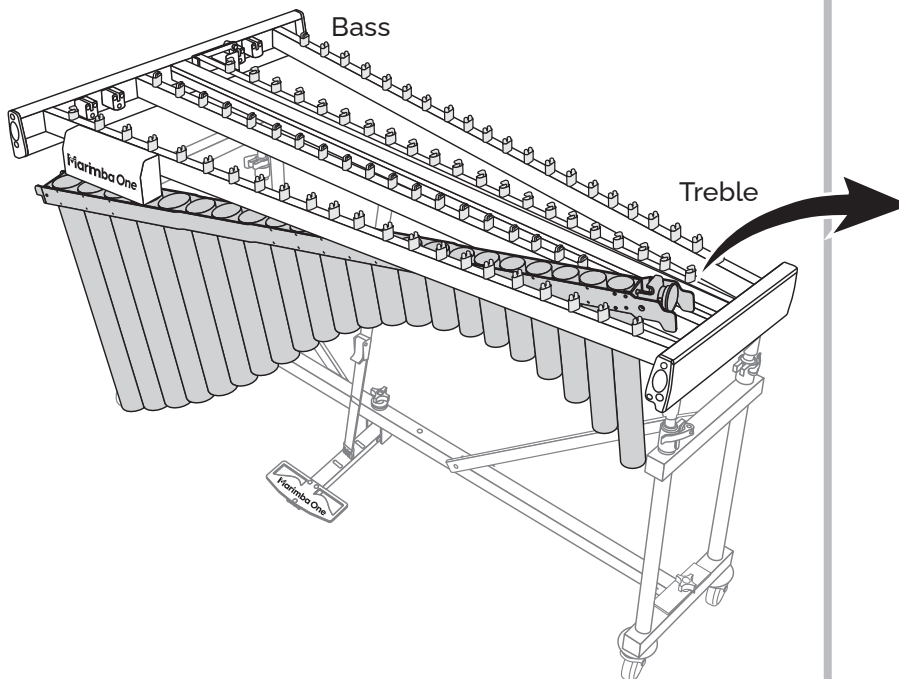

20

**INSERT RESONATORS**

Insert resonators into the treble headboard.

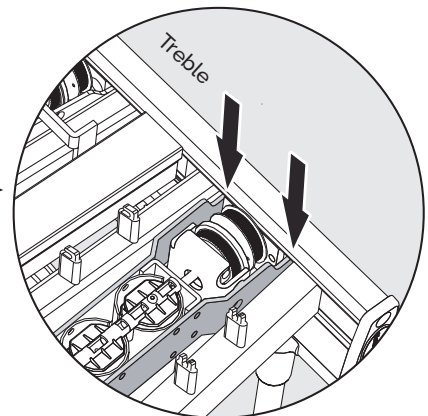

## 21 LIFT BASS END

Lift bass end of resonators above top edge of bass headboard.

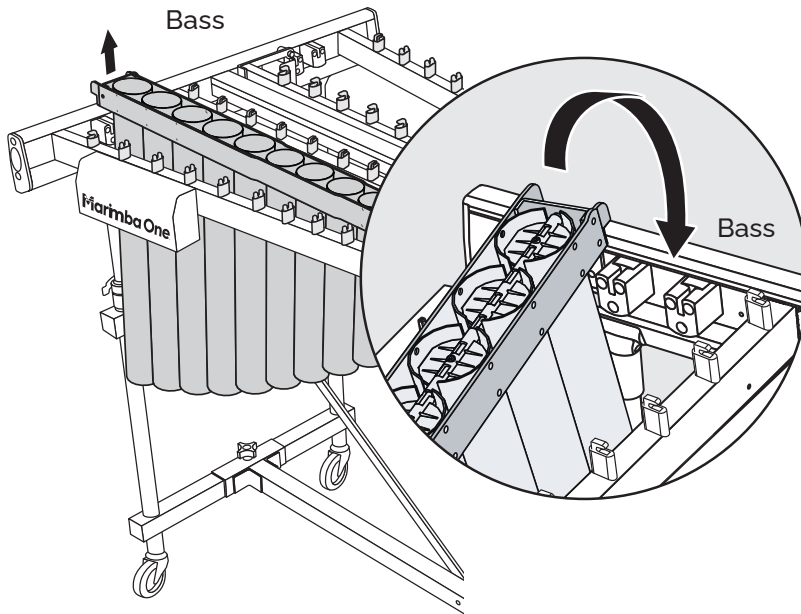

## 22 INSERT RESONATORS

Insert resonators into slots on bass headboard.

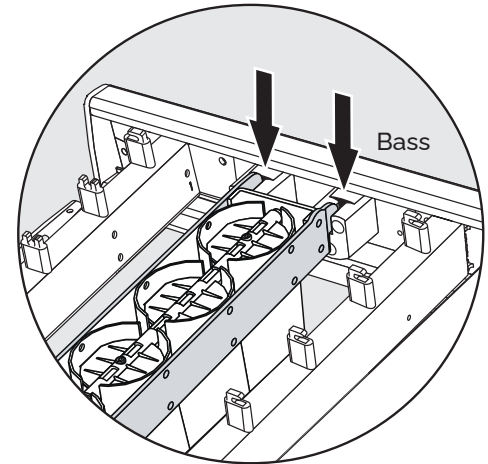

## 23 IDENTIFY ACCIDENTAL RESONATOR BANK

Repeat steps 19 through 22.

## 24 CHECK FIT

Push down on the resonators on the treble end to make sure they are fully in place.

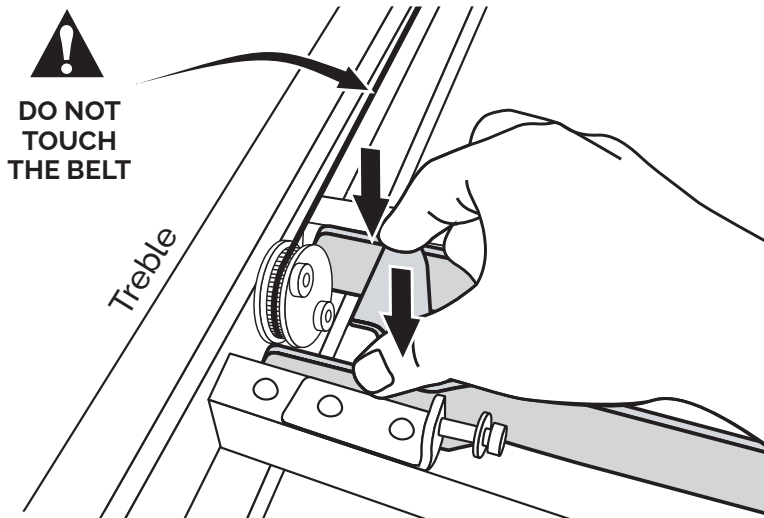

### MAGNETIC DRIVE SYSTEM

Once the resonators are placed into the frame, the resonators fans are ready to rotate.

Our patented Magnetic Drive System eliminates the need for hooking up belts and cables.

## KEYBOARDS

### 25 POSITION NATURAL KEYBOARD

Hold cords, push pedal down with foot, lay keyboard onto rails 1 and 2.

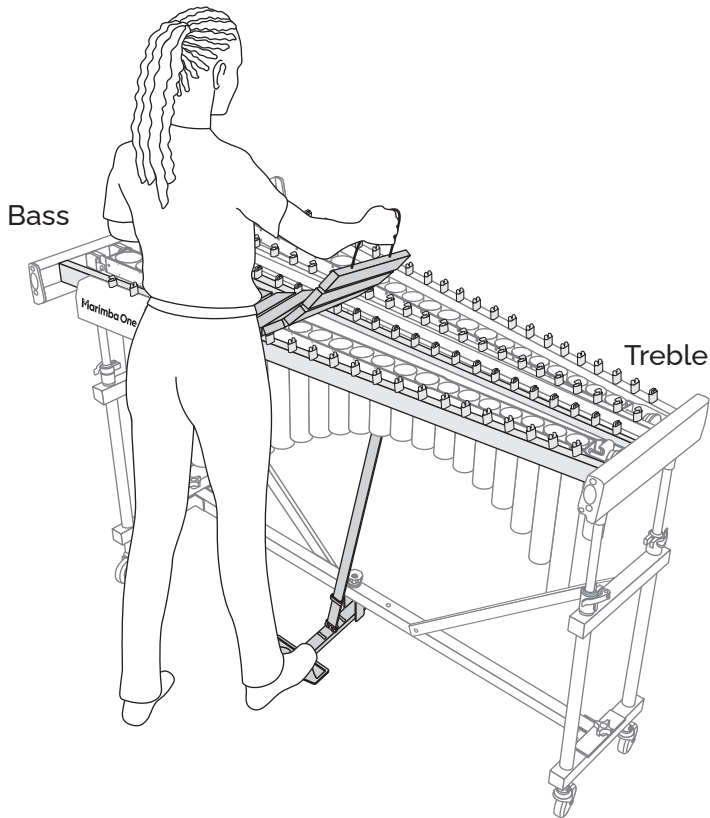

### 26 SECURE TREBLE END

Slide cord around corner jacks on treble end.

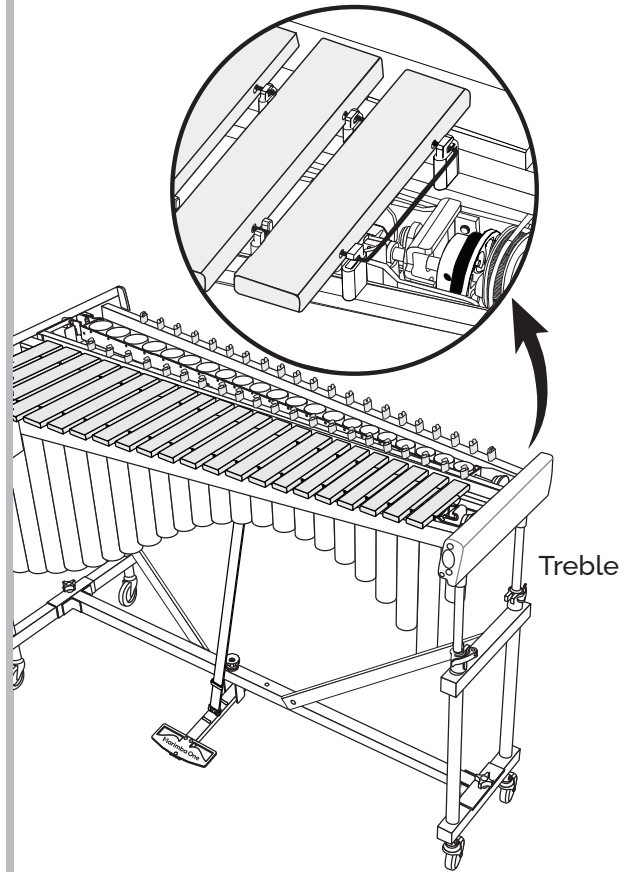

### 27 POSITION BARS ON RAILS

Place bars between rail jacks.  
Set cord into slots on rail jacks.

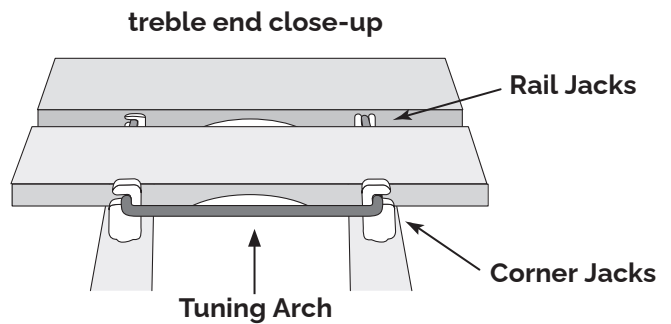

### 28 SECURE BARS TO RAILS

At bass end, pull cord evenly taut and then hook springs together and then slip over corner jacks to secure cord.

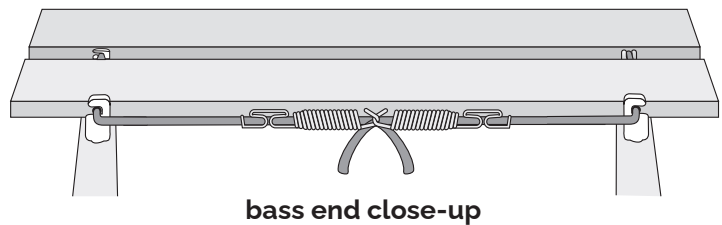

### 29 FOLLOW SIMILAR PROCEDURE FOR ACCIDENTAL BARS

**NOTE:** For accidental bars, bars are *only placed over resonators with a plug.*

## DAMPING PRESSURE TENSION KNOB

30

### TENSION KNOB

The tension knob is set at the factory for full damping pressure.

Turn clockwise for less damping pressure and counter-clockwise for more dampening pressure.

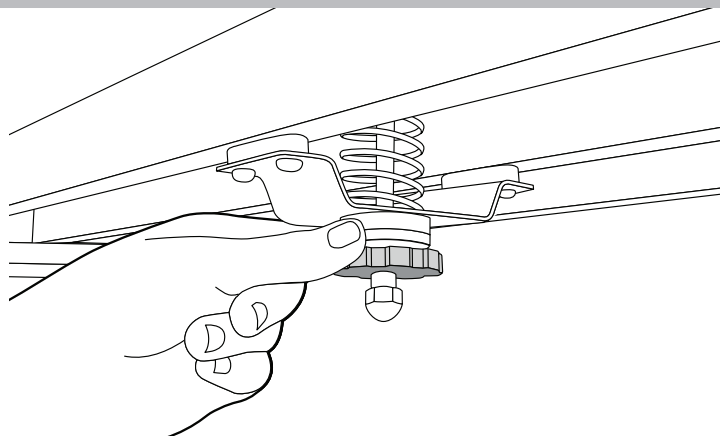

31

### ADJUSTING THE SUSTAIN AT THE BASS OR TREBLE ENDS OF INSTRUMENT

The damper bar is set at the factory for even damping across the keyboard.

Adjust balance of sustain by turning the adjustment screw located at bass end.

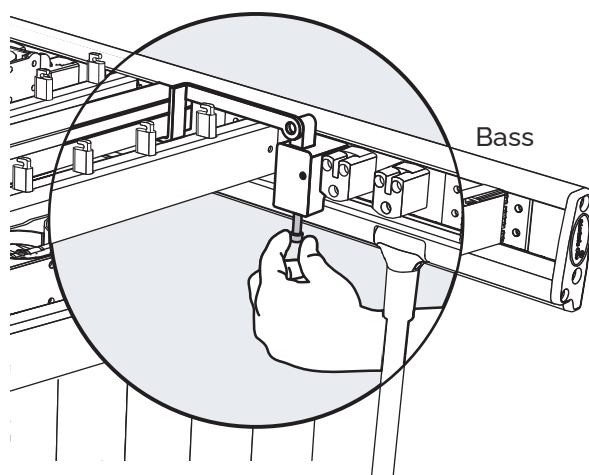

**Lower the adjustment knob**  
for more bass sustain and less  
treble sustain.

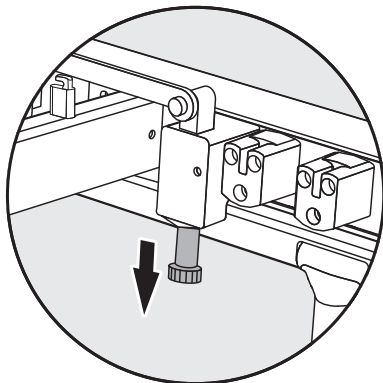

**Raise the adjustment knob**  
for less bass sustain and more  
treble sustain.

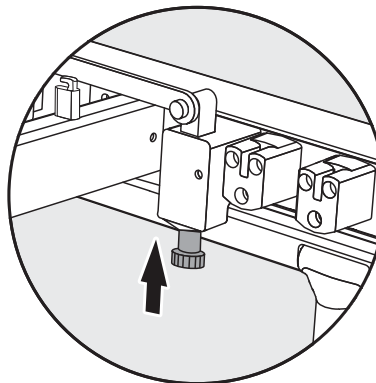



## HEIGHT ADJUSTMENT

32

### RAISING/LOWERING YOUR VIBRAPHONE

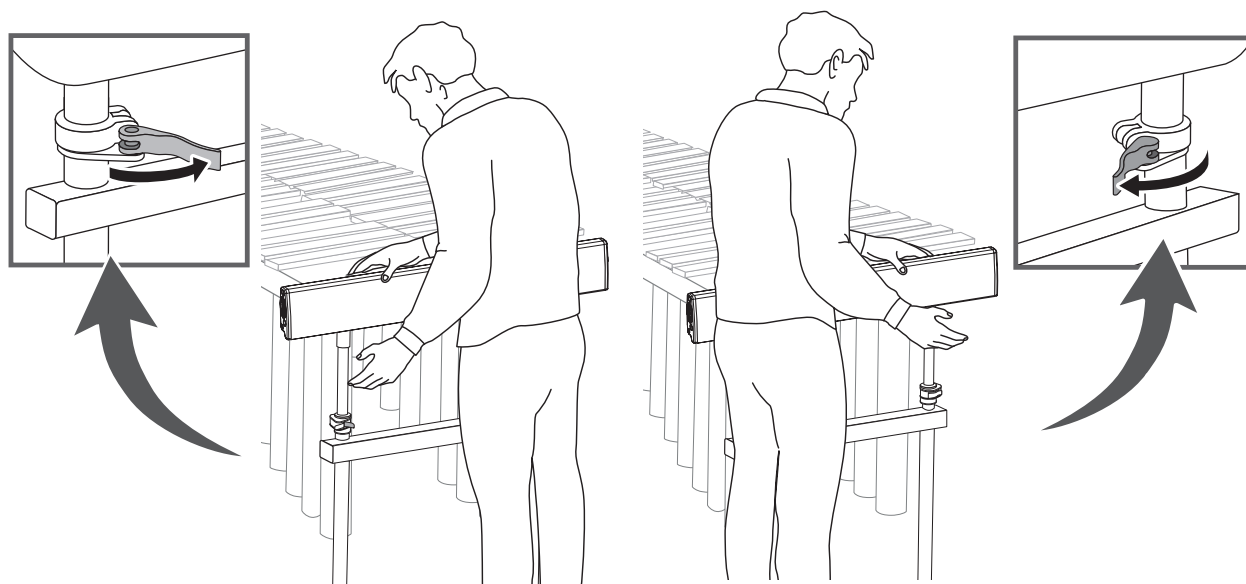

a

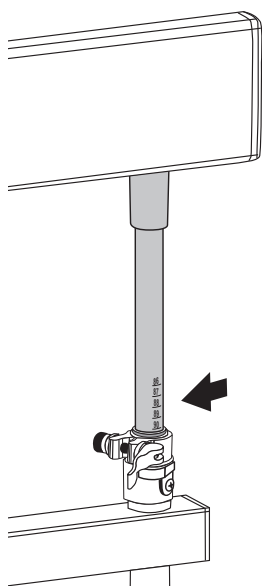

Locate the Izzy Height Adjustment™ clamp on the frame.

b

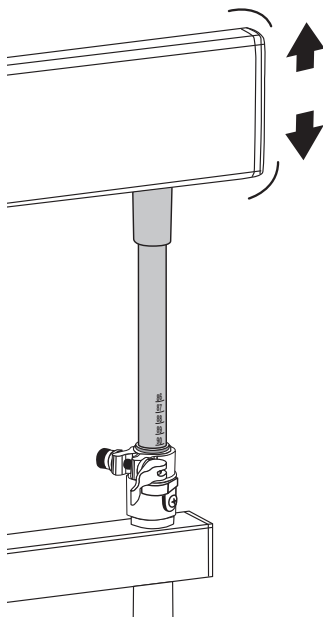

Gently lift or push down to raise or lower.

c

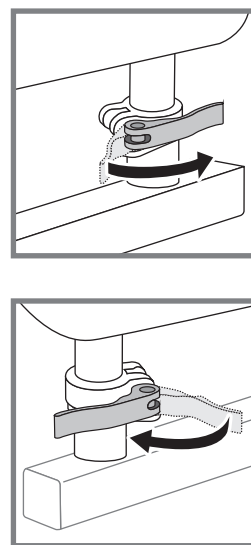

Close levers when desired height is achieved.

## USING THE MOTOR CONTROL BOX

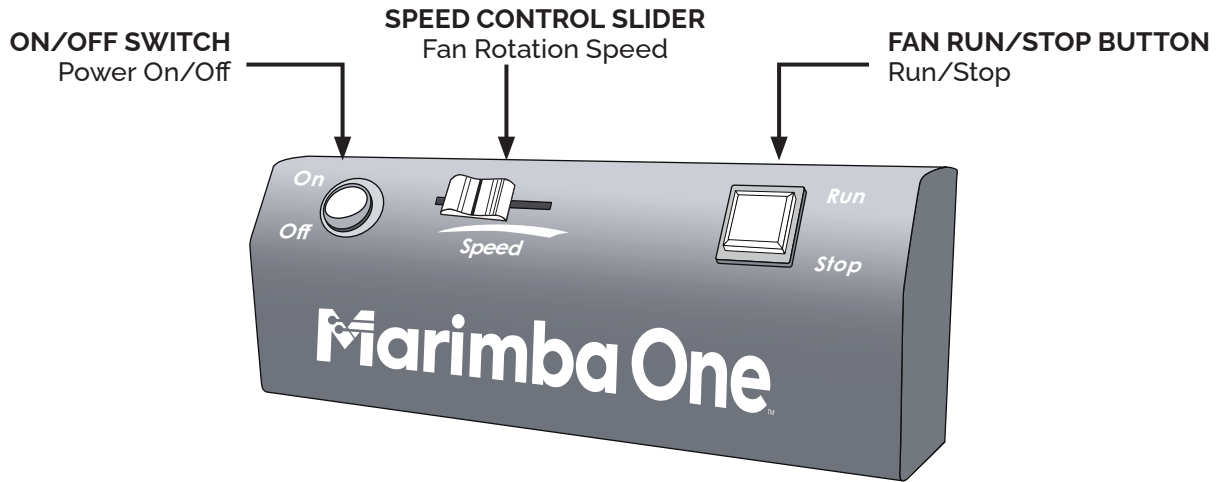

32

### TO TURN POWER ON

Push **On/Off Switch** to **ON** position.

ON/OFF SWITCH



33

### TO MAKE FANS ROTATE

Push **Run/Stop Button** **IN** to **RUN** (glows green) and use the slider to control fan speed. The One Vibe fans always stop in the 12 o'clock/vertical position when you push the **Run/Stop Button** again to pop out to **STOP** (glows red).

**NOTE:** To avoid the fans stopping in random positions, do not turn the **On/Off Switch** to the **OFF** position when playing the One Vibe.

FAN RUN/STOP BUTTON

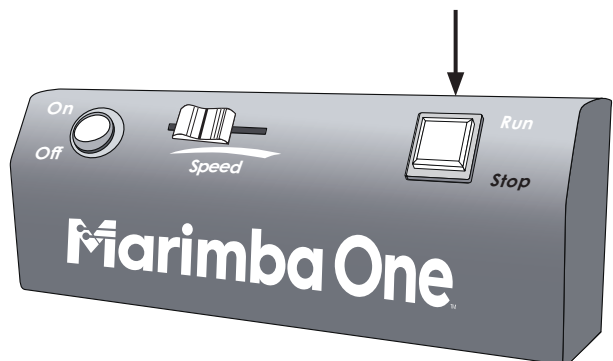

## AFTER ASSEMBLY CARE & MAINTENANCE

- ✓ bar cord tension
- ✓ cleaning

- ✓ moving the vibraphone

### bar cord tension

Over time, as you play your instrument, the cord that suspends the bars may loosen and need to be adjusted. To increase tension in the bar cord, use the cleats behind the springs to take up slack in the cord.

#### 1 UNHOOK SPRINGS

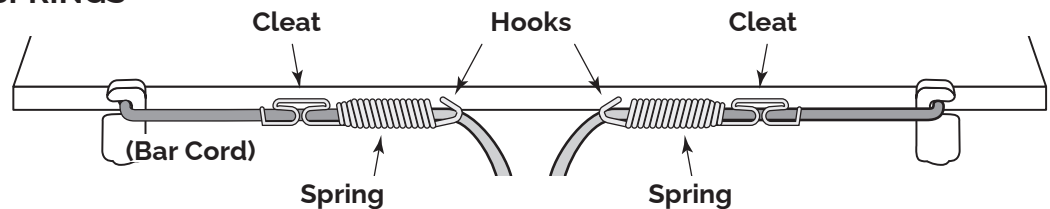

#### 2 FORM LOOP IN CORD

At cleat, pull cord to make enough slack to form a loop.

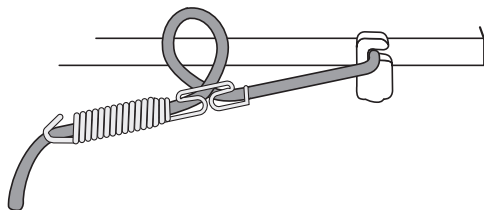

#### 3 SLIP LOOP OVER CLEAT

Slip the loop down around the cleat. Pull the cord taut.

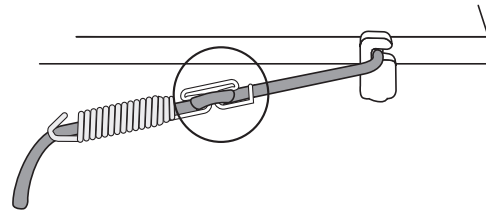

#### 4 RE-HOOK SPRINGS

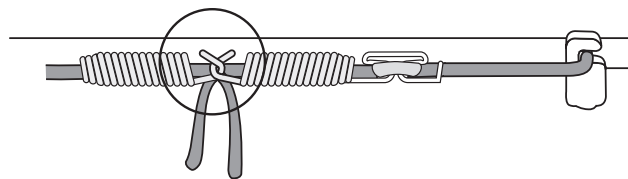

### vibraphone cleaning

**USE A SOFT COTTON CLOTH OR TOWEL DAMPENED WITH WATER ONLY.**

**Do not use commercial cleaners on your vibraphone!**

### moving the vibraphone

**THE VIBRAPHONE SHOULD ONLY BE LIFTED BY THE END FRAMES.**

When the vibraphone is moved, pass **SLOWLY** through doorways, over doorjambs, electrical cords, and uneven surfaces.

# WARRANTY

**YOU ARE THE OWNER OF ONE OF THE FINEST VIBRAPHONES IN THE WORLD  
THE FOLLOWING WARRANTY PROTECTS YOUR INVESTMENT  
PLEASE READ IT CAREFULLY**

## **Marimba One**

Manufacturer of the world's finest percussion keyboards and mallets

**MARIMBA ONE WARRANTS ONLY TO THE ORIGINAL PURCHASER  
THAT THIS INSTRUMENT IS FREE FROM DEFECTS IN MATERIALS  
AND/OR WORKMANSHIP AS FOLLOWS:**

1. During a period of twelve (12) months from the date of receiving your instrument, Marimba One® will pay all labor and materials necessary to repair any defective instrument or part thereof. We will repair a defective instrument or part at the location of our factory. The purchaser must pay all shipping charges to and from our factory in advance.
2. During a period of twelve (12) months from the date of receiving your instrument, Marimba One® will replace at no charge any bar that fails to perform according to acceptable musical standards. Marimba One® will replace any defective bar upon request by the purchaser. The purchaser must return the defective bar to the location of our factory upon receipt of the replacement bar. The purchaser must pay all shipping charges to and from our factory in advance.
3. Natural variation occurring in materials which do not affect the musical performance of the instrument shall not be considered defects, Marimba One® reserves the right to inspect any instrument claimed to be defective to determine if the cause is a manufacturing defect. Excluded from this warranty are all defects other than manufacturing defects. Specifically excluded are defects occurring as a result of use other than normal use, any unauthorized alteration or repair of the instrument, defects occurring in the course of shipping, and other similar defects not related to the manufacture of the instrument.

**REPAIR OR REPLACEMENT AS PROVIDED UNDER THIS WARRANTY IS THE EXCLUSIVE REMEDY OF THE PURCHASER, MARIMBA ONE SHALL NOT BE LIABLE FOR ANY INCIDENTAL OR CONSEQUENTIAL DAMAGES FOR BREACH OF ANY EXPRESS OR IMPLIED WARRANTY. EXCEPT TO THE EXTENT PROHIBITED BY APPLICABLE LAW, ANY IMPLIED WARRANTY OF MERCHANTABILITY OR FITNESS FOR A PARTICULAR PURPOSE IS LIMITED IN DURATION AND SCOPE TO THE DURATION AND SCOPE OF THIS WARRANTY. THIS WARRANTY IS NONTRANSFERABLE AND VALID ONLY TO THE ORIGINAL PURCHASER.**

## **Marimba One**

Telephone: (707) 822-9570

Email: [percussion@marimbaone.com](mailto:percussion@marimbaone.com)

### **LOCATION**

901 O Street, Arcata, CA 95521 - U.S.A.

### **MAILING ADDRESS**

Post Office Box 786, Arcata, CA 95518 - U.S.A.

**INSTRUMENT SERIAL NO.:**